



# Trench & Perimeter Heating

Part of the Periwarm range

**HCP**

HCP is the specialist heating and cooling division of SAS International Limited.

Specialising in convective and radiant heating and cooling solutions we offer an unprecedented combination of value, product quality and application expertise.

A UK owned and based organisation with manufacturing plants across the country the HCP sales office is based in St Leonards on Sea, East Sussex.

We have supplied the heating and cooling as a combined room comfort solution on many of the U.K.'s leading building developments. Some of our major product installations are pictured opposite:

## Index

### Trench Heating Systems

- Features 4
- Components 5
- Applications & Design Solutions 6
- Performance Data 7
- Options 8

### Electric Trench

- Features 9
- Performance Data 10

### Perimeter Heating Systems

- Features: STG, TG, FG 11
- Components 12-13
- Options 14
- Performance Data 15

### Grilles 16

### Finned-Tube Elements 17

### Design Applications 18

### Technical Specifications 19



Scottish Gas HQ Edinburgh  
Vodafone World HQ, Newbury  
Marks & Spencer HQ  
Paddington



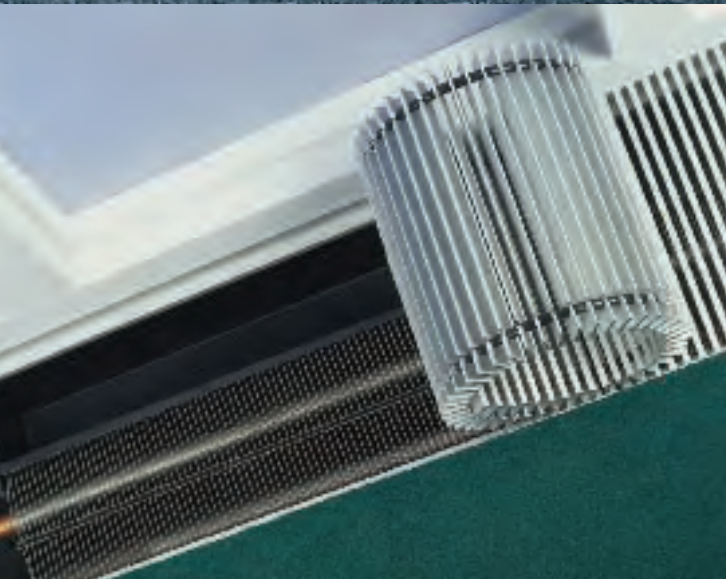

# Trench Heating

## FEATURES

- 9 standard systems
- Wide range of outputs
- Efficient aluminium fin
- Modular options
- Heavy gauge steel construction
- Low maintenance
- 15mm, 22mm or 28mm constant diameter tubing
- Extruded aluminium profiled grille
- Roll-up, rigid and linear grille available
- Suitable for screeded or raised access floors
- Electric element option
- Mitred and curved units available
- Easily levelled

# Trench Heating

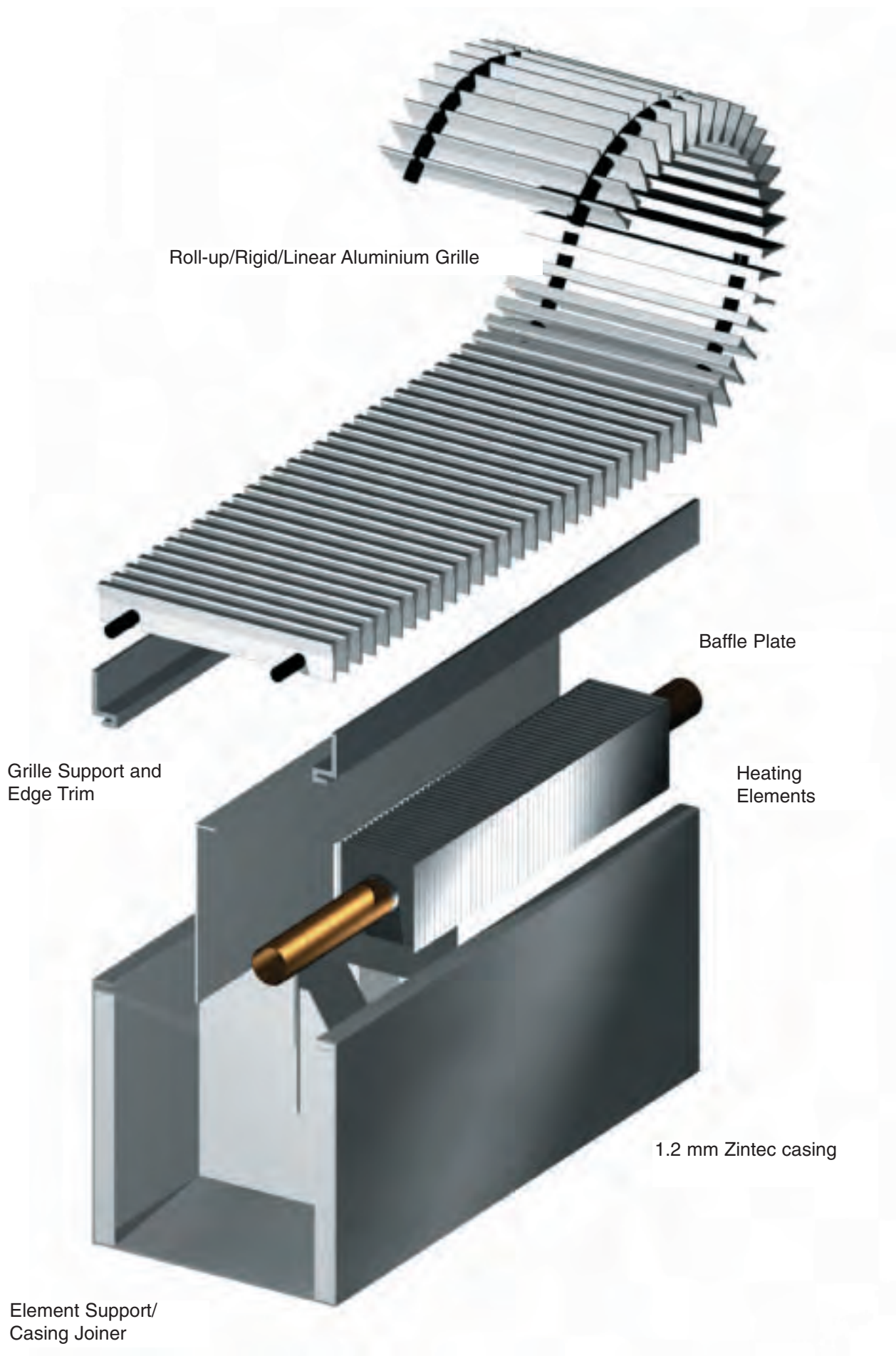

## APPLICATIONS

The HCP range of Periwarm trench heating systems offers LPHW or electric heating elements, and can be fully recessed, semi recessed or floor mounted.

Ideal for combating cold down draughts and condensation, characteristics often associated with full and half height glazing, the Periwarm trench system provides an effective heat source where wall space is limited.

For both new and refurbishment projects, HCP offer the attractive, versatile and extensive range of Periwarm trench heating systems.

## DESIGN SOLUTIONS

Design and adaptability are fundamental to the HCP philosophy of customer commitment, so whatever your space restriction or output requirement we can design a system to suit.

Should an installation require a special unit to be made, HCP frequently design and manufacture a prototype unit in advance of contract in order for the specifier, contractor and client to comment on the system and ensure maximum satisfaction.

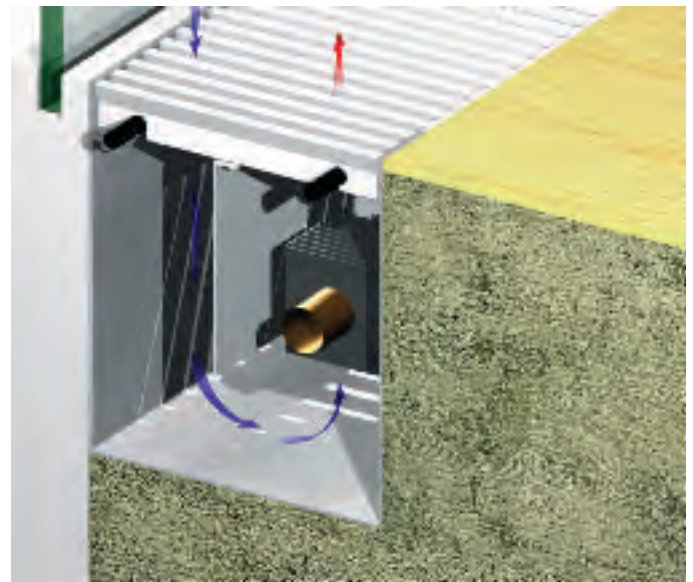

Fully recessed

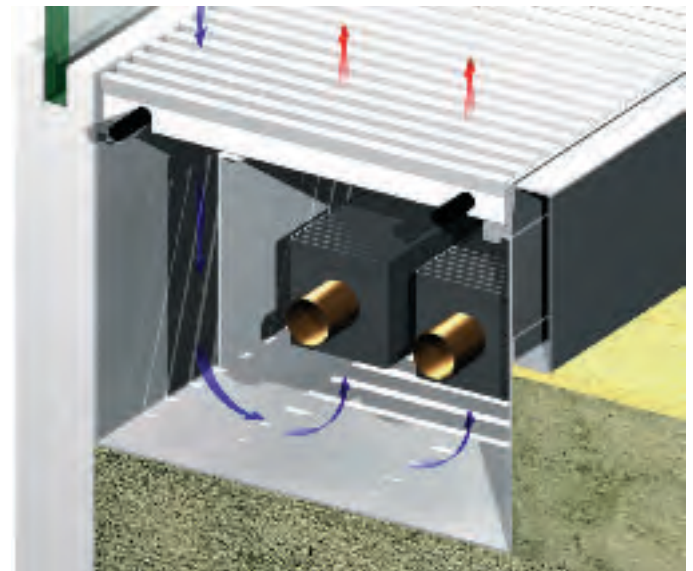

Semi recessed

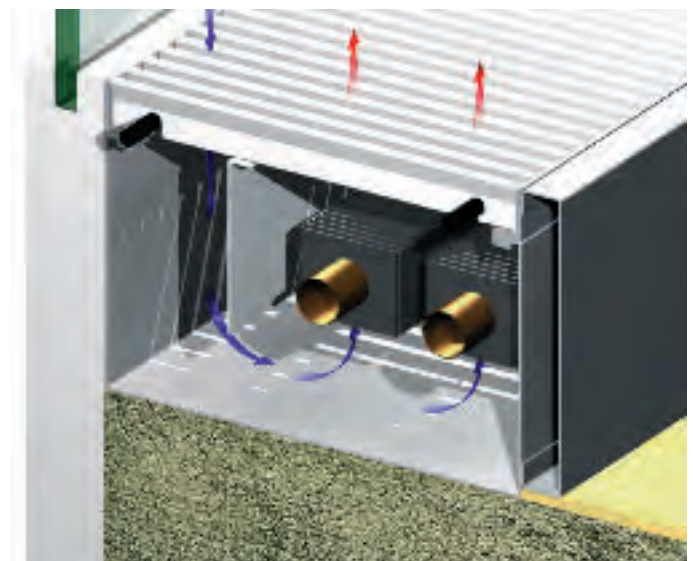

Floor mounted

# Trench Heating

## PERFORMANCE DATA

Model	*Output watts/metre	Tube Diameter mm
LTU/J	250	15 or 22
LTU/JJ/S	380	15 or 22
LTU/N	485	15, 22 or 28
LTU/W	645	22 or 28
LTU/JJ	645	15 or 22
LTU/FF	645	15 or 22
LTU/FN	805	15 or 22
LTU/NN	970	15, 22 or 28
LTU/WW	1290	22 or 28

\* All outputs in watts/metre are for finned length of element and based on LPHW 80° m.w.t., 20°C e.a.t. and 1.0m/s water velocity.

CORRECTION FACTORS			
Variations in water velocity		Variations in $\Delta T$	
Water Velocity in metres/sec	Correction Factor	$\Delta T$ m.w.t. - e.a.t. K	Correction Factor
0.08	0.90	30	0.38
0.10	0.91	35	0.47
0.15	0.92	40	0.57
0.25	0.93	45	0.67
0.28	0.94	50	0.77
0.30	0.95	55	0.88
0.35	0.96	56	0.90
0.50	0.97	57	0.93
0.75	0.99	58	0.95
1.00	1.00	59	0.98
1.35	1.02	60	1.00
2.00	1.03	65	1.12
		70	1.24
		75	1.34
		80	1.47

## DIMENSIONS

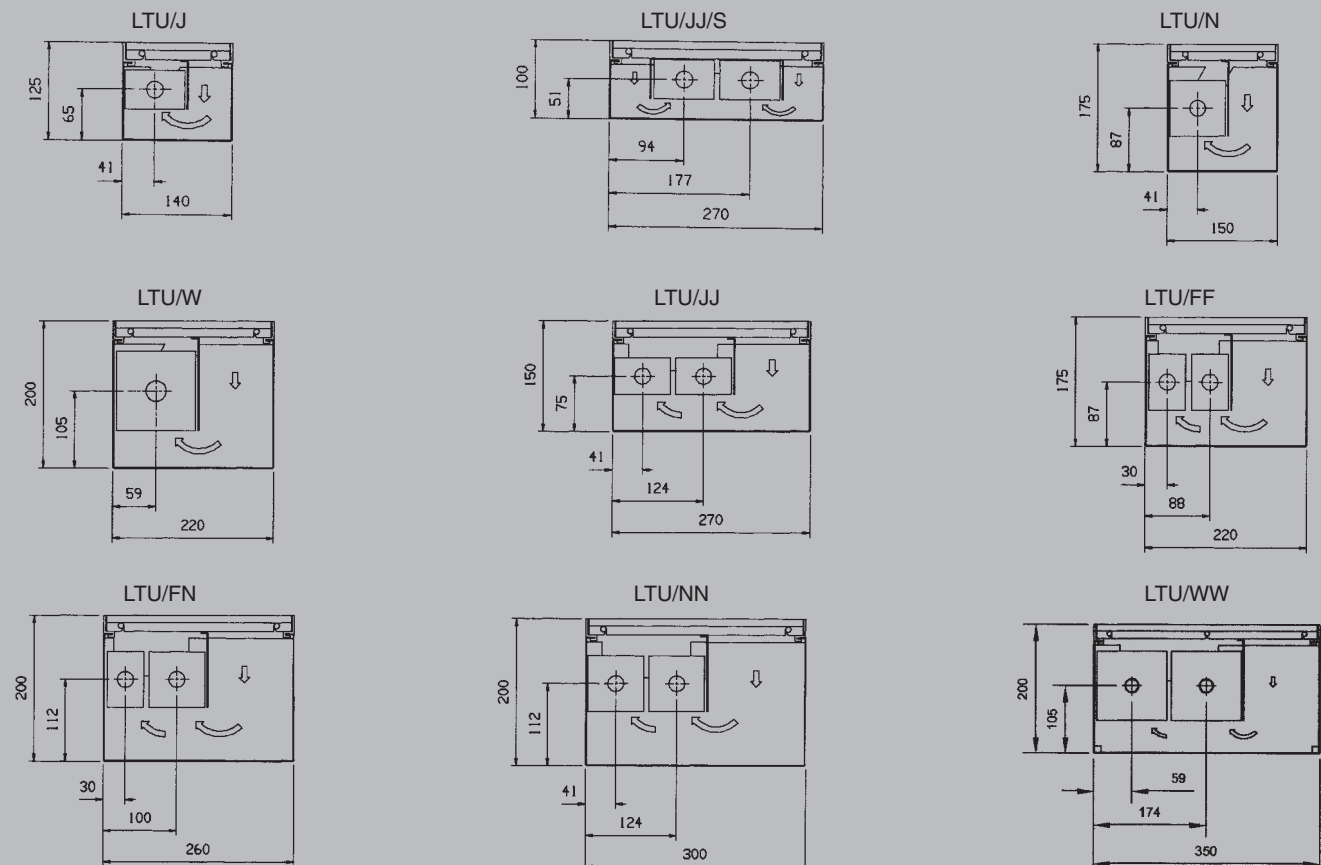

# Trench Heating

## OPTIONS



Front Panel

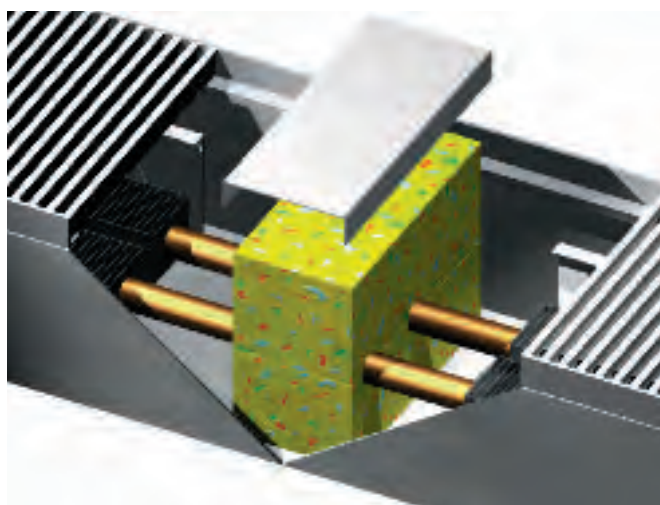

Partition cover plates and casing baffles



Cable trays



Linear aluminium grilles

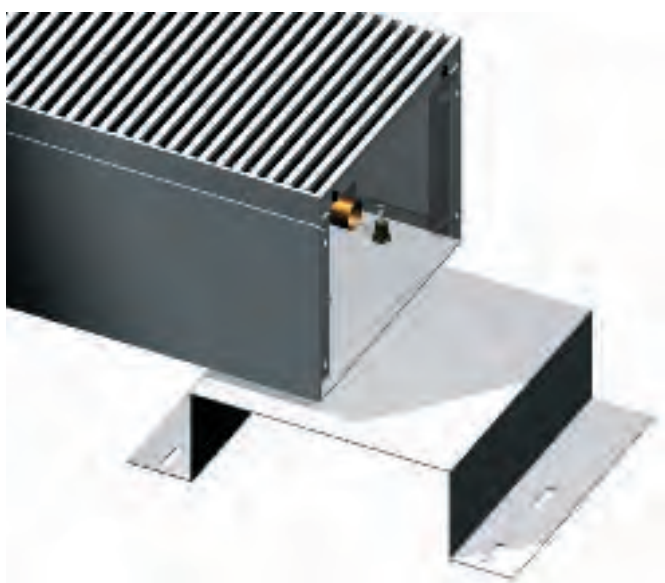

Cantilevered casing support

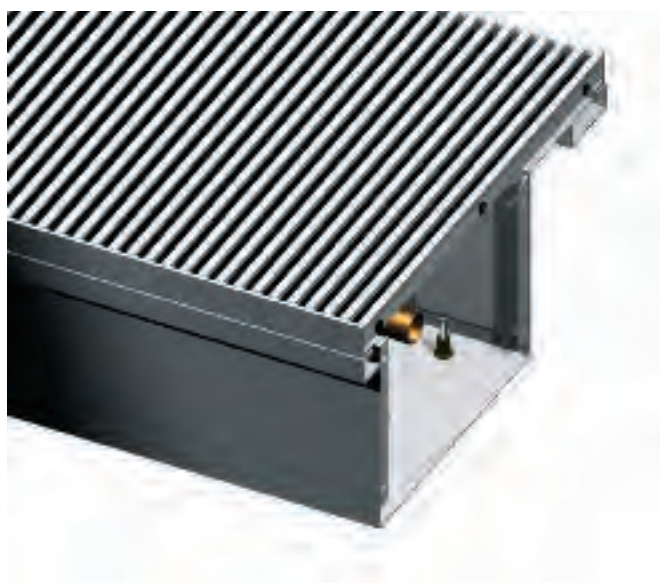

Over sized grilles

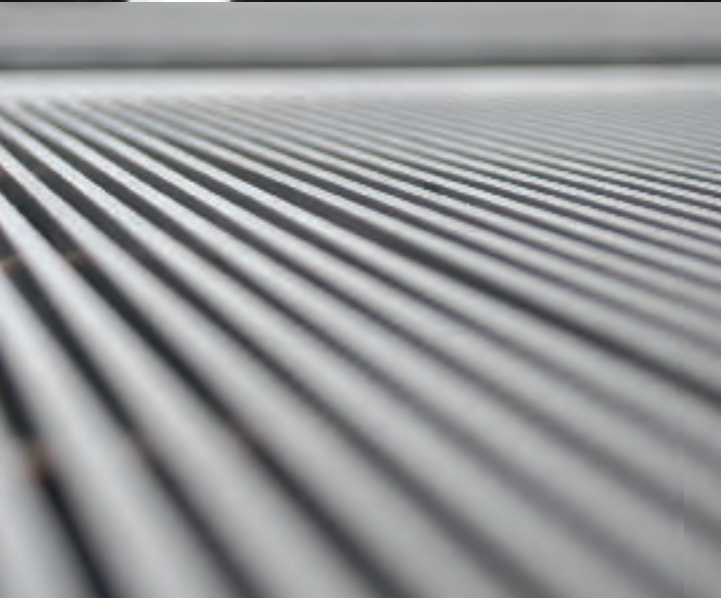
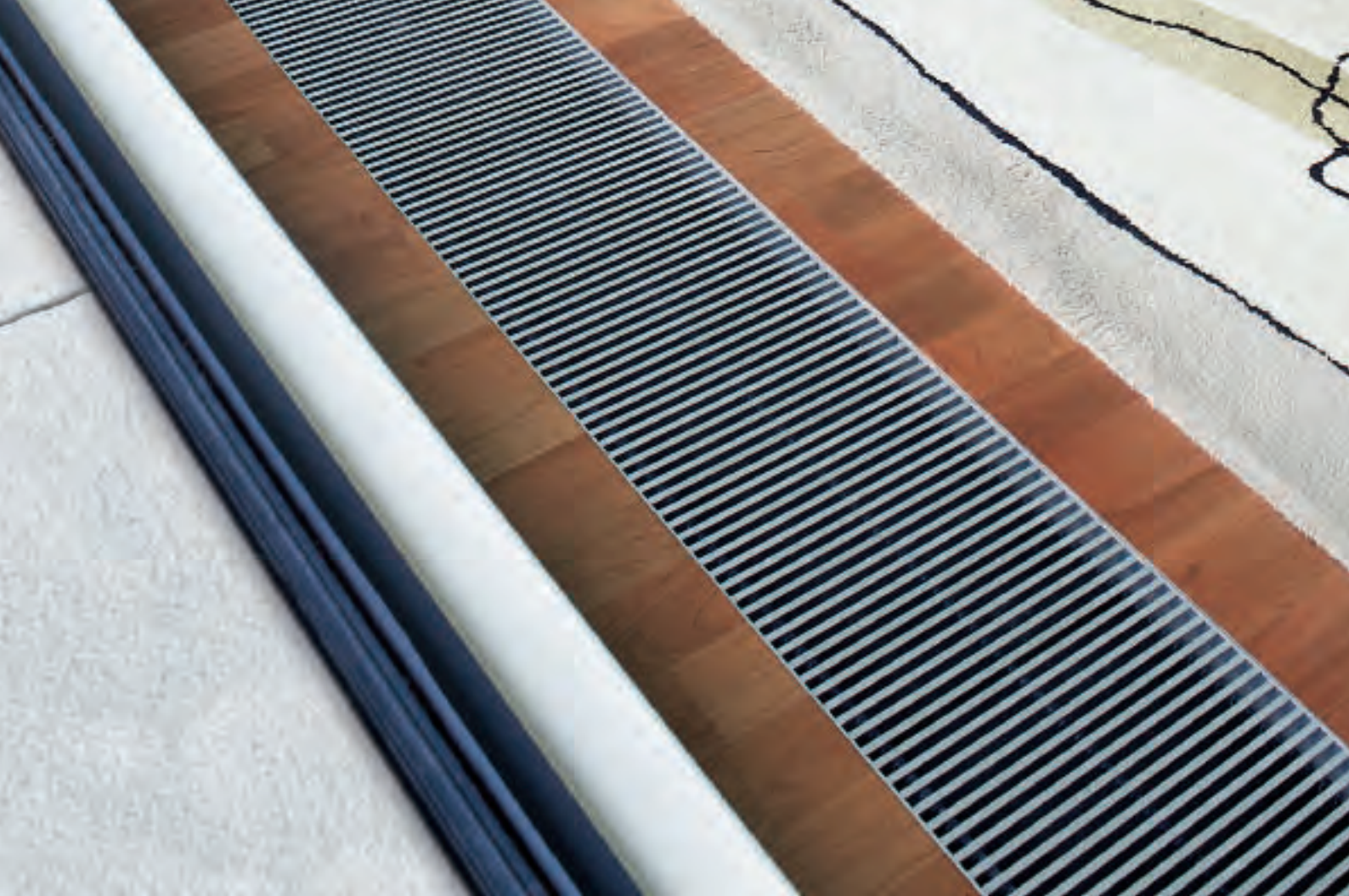

# Electric Trench

## FEATURES

- Fully pre-wired, tested and assembled
- Inbuilt temperature thermostat
- High Temperature safety cut out
- Protective mesh guard
- Enclosed section for control wiring
- Pencil proof grille spar spacing
- Extruded aluminium profiled grille
- Custom design solutions
- Mitred and curved units available
- Heavy gauge steel construction
- Casing Lengths up to 3000mm
- Higher heat outputs available

# Electric Trench

## PERFORMANCE DATA

Ref	Casing Length (mm)	Casing Width (mm)	Casing Height (mm)	Heat output per unit (watts)
LTU/E100	1000	200	100	356
	1500	200	100	586
LTU/E150	1000	200	150	406
	1500	200	150	667
LTU/E200	1000	200	200	488
	1500	200	200	803

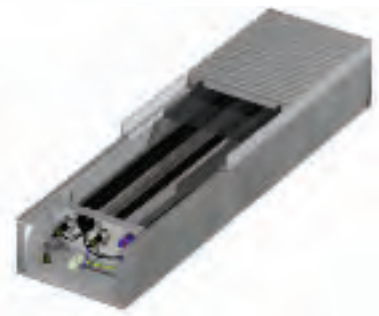
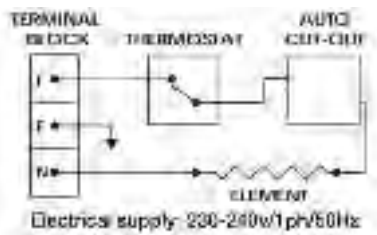

If the dimensions or heat outputs outlined fall outside the requirements of your application, please contact us to discuss a HCP design solution.

## DIMENSIONS

LTU/E100

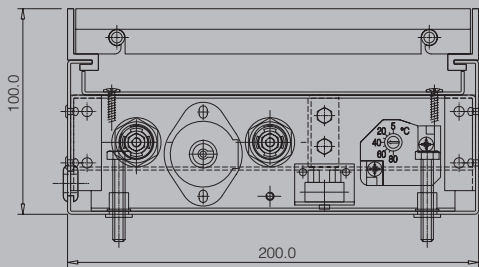

LTU/E150

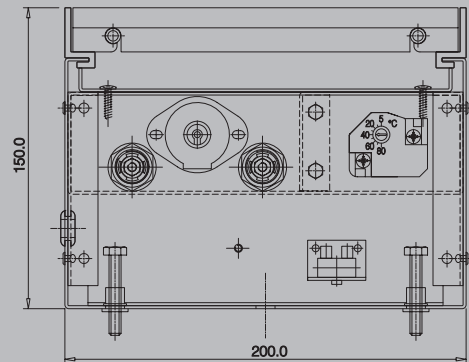

LTU/E200

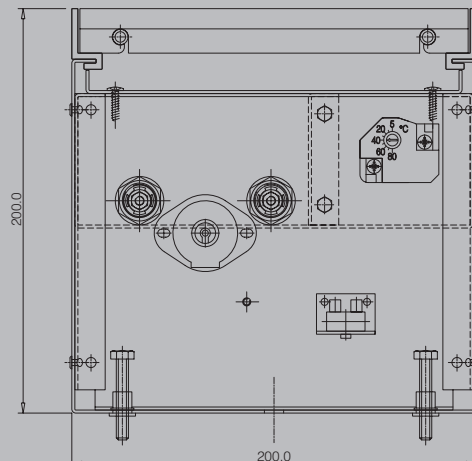



# Perimeter Heating

FEATURES: STG, TG, FG

- Choice of 5 LPHW element sizes
- Single or double layer element option
- Wide range of standard polyester powdercoat colours
- Efficient aluminium fin
- 15mm, 22mm or 28mm constant diameter tubing
- Designed to fit all types of building
- Low maintenance
- 40mm - 123mm depth
- Extruded aluminium profiled grilles
- Punched slotted outlets available
- Electric element option
- Modular options
- Heavy gauge steel construction



Pictures: Top - Front grille, Middle - Top grille, Bottom - Sloping top grille

# Periwarm Wall

## APPLICATIONS

The HCP range of systems offer low pressure hot water or electric heating elements which can be wall mounted or independently supported at low, medium or high level to give continuous heating along a wall or walkway.

Ideal for combating cold down draughts and condensation, characteristics often associated with full and half height glazing, the Periwarm wall mounted system provides an effective heat source for both new and refurbishment projects.

**Heating Elements** are made from copper tube with aluminium fins. They take standard capillary fittings

**Wall Mounting Brackets**

**Heating Element Hangers**

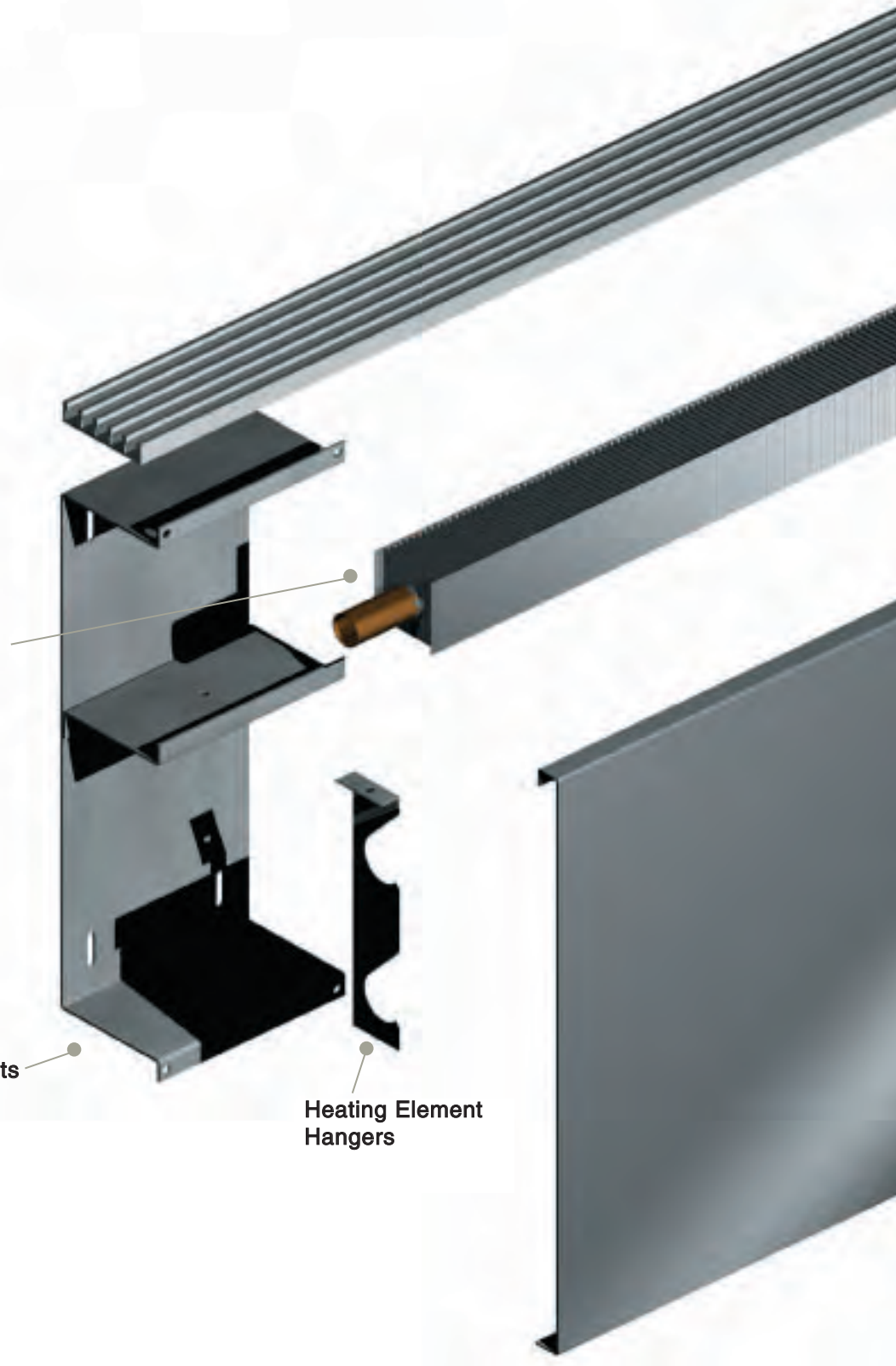

# Mounted Systems

## DESIGN SOLUTIONS

Design and adaptability are fundamental to the HCP philosophy of customer commitment so whatever your space restriction or output requirement we can design a system to suit. Should an installation require a special unit to be made, HCP frequently design and manufacture a prototype unit in advance of contract in order for the specifier, contractor and client to comment on the system and ensure maximum satisfaction.

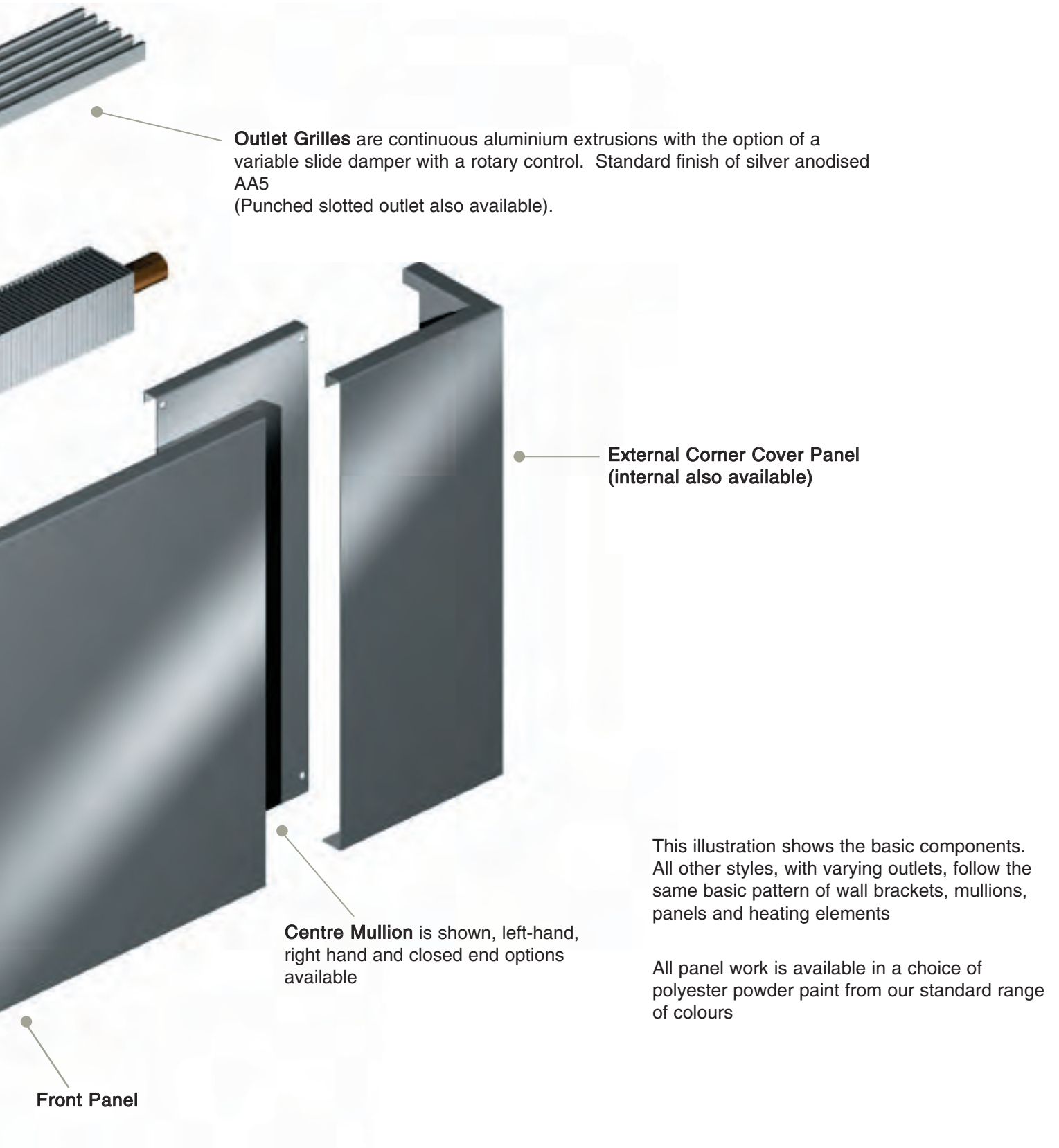

# Perimeter Heating

## OPTIONS



High & low level cable duct

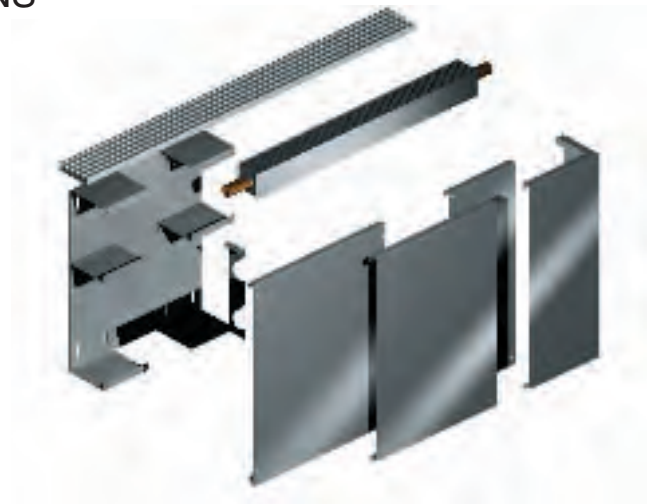

Split mullion for partition points



Air circulation dampers



Separate cable duct. (Multi cable duct also available)

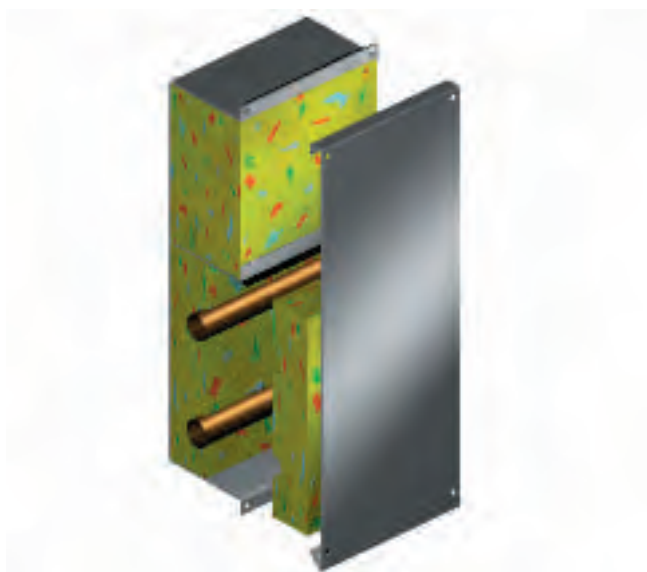

Acoustic baffle to counter transfer of noise

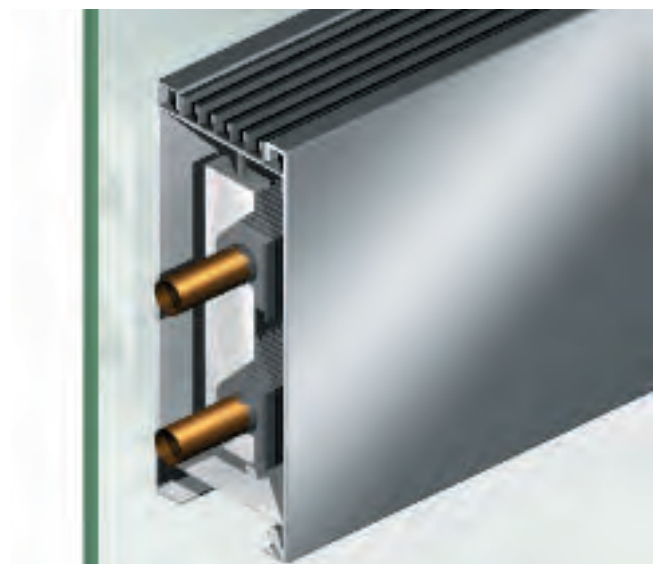

Full height glazing applications

# Perimeter Heating

## PERFORMANCE DATA

HEAT OUTPUTS - WATTS/FINNED METRE					
Unit Height (mm)	Element	Element Type			
		A*	F & J	N	W
150	SR	280	482	684	-
200	SR	300	523	739	898
250	SR	320	554	784	954
250	DR	355	616	872	-
300	SR	335	582	825	1002
300	DR	390	676	955	1165
350	SR	350	607	860	1044
350	DR	425	733	1037	1261
400	SR	365	630	892	1082
400	DR	450	784	1112	1350
450	SR	375	650	920	1119
450	DR	480	833	1180	1434
500	SR	385	668	947	1151
500	DR	505	880	1245	1513
550	SR	395	686	972	1180
550	DR	535	923	1307	1589
600	SR	405	703	994	1208
600	DR	560	966	1367	1661
650	SR	415	718	1016	1235
650	DR	580	1006	1425	1731
700	SR	425	733	1036	1260
700	DR	605	1045	1479	1798

SR = Single Row  
DR = Double Row

Based on LPHW 80°C m.w.t.  
20°C e.a.t. and 1.0 m/s water velocity  
Grille free area 33%

CORRECTION FACTORS			
Variations in water velocity		Variations in $\Delta T$	
Water Velocity in metres/sec	Correction Factor	$\Delta T$ m.w.t. - e.a.t. K	Correction Factor
0.08	0.90	30	0.38
0.10	0.91	35	0.47
0.15	0.92	40	0.57
0.25	0.93	45	0.67
0.28	0.94	50	0.77
0.30	0.95	55	0.88
0.35	0.96	56	0.90
0.50	0.97	57	0.93
0.75	0.99	58	0.95
1.00	1.00	59	0.98
1.35	1.02	60	1.00
2.00	1.03	65	1.12
		70	1.24
		75	1.34
		80	1.47

DIMENSIONS (MM)					
Ref	B	C	D	E	Tube Dia
A	40	50	77	96	15 or 22
F	60	50	77	96	15 or 22
J	90	50	51	70	15 or 22
N	90	65	77	96	15, 22 or 28
W	120	75	83	127	22 or 28

**Notes:**

**A\* = STG and FG not available in size A element**

Table of outputs is for TG and HG:

For STG unit: Use unit height minus 50mm

For FG unit: Use panel height in place of unit height

For low level integral cable duct units, reduce by height of cable duct.

### Sloping Top Grille (STG)

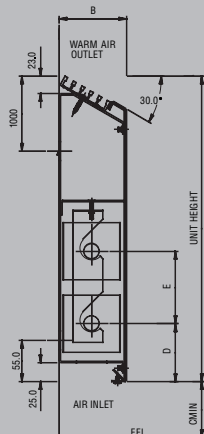

### Top Grille (TG)

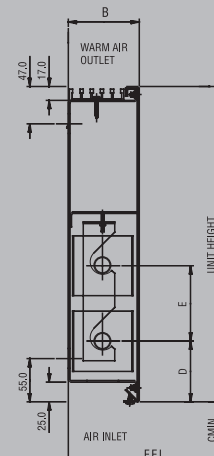

### Front Grille (FG)

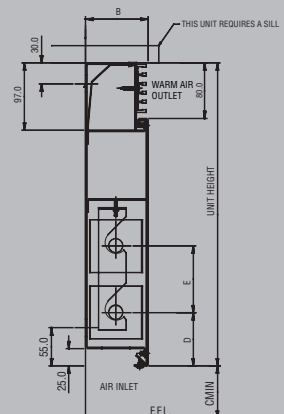

# Grilles

## Wall mounted perimeter heating grilles

Manufactured in aluminium extrusions, the grilles are simple to fix, easy to join and very robust.

### Sizes

Any length can be supplied up to a maximum of 5 metres, but for ease of handling, it is usually supplied in 3 metre lengths.

### Joining

Extruded channels 75mm long fit into the ends of each grille to connect to the next grille section.

### Finishes

Standard grilles are silver anodised but other finishes are available including polyester powder coat and 'shadow-line' with the core painted black and top finished.

A	Width of bar	3.5mm
B	Intermediate land	13.0mm
C	Length of punched slot	89.0mm
D	Width of punched slot	5.5mm
E	Height of grille bars	14.0mm
F	Width of grille	GA/1 42.75mm GB/1 68.75mm GC/1 107.75mm

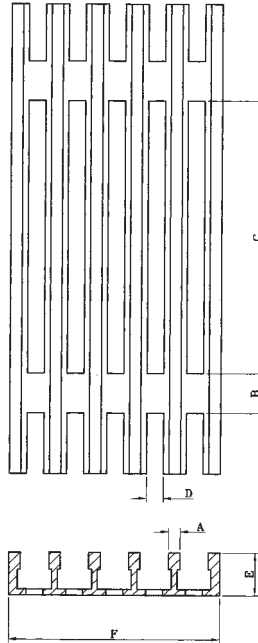

GA/1



GB/1



GC/1



### TYPE 'AN'

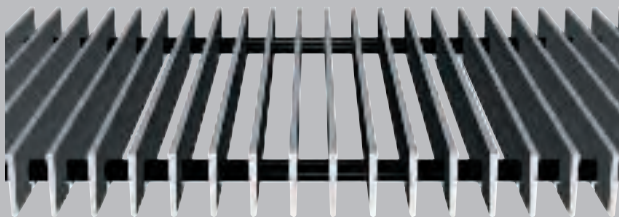
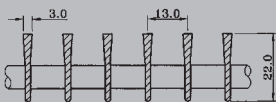

### TYPE 'AW'

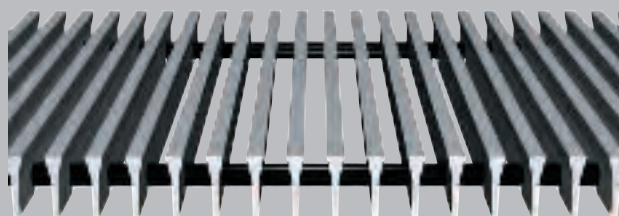
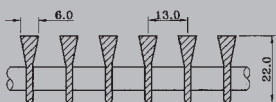

## Aerofoil grilles

Two styles of grille bar are available, both manufactured from extruded aluminium. The shape of bar particularly suits grilles for use in fan-powered air systems. Trench grilles are available in rigid or roll up form. A linear grille is also an option.

Conventional bar spacings are shown in the drawing but where it is required to achieve a different free area, the pitch of the bars can be manufactured to other dimensions.

### Sizes

Lengths up to 3.6m for roll up and 1.5m for rigid available and widths to suit each application.

### Finishes

As per wall mounted grille finishes plus stainless steel.

# Finned-Tube Elements

Heating by natural convection through the medium of hot water is achieved by the use of finned-tube elements mounted in a suitable enclosure. The finned tubes are available in five sizes with varying tube diameters.

The returned edges of the fins and the bonding by expansion to copper pipe make a highly efficient and mechanically-strong element.

Protection from dust and rubble during building operations is provided by shrink wrapping the element.

The outputs listed on page 7 are obtained from the elements at the panel heights shown. The stack height is the dimension between the bottom of the fins and the air outlet.

(see diagram A)

A variation of the stack height will affect the output. Varying the panel height but not changing the stack height will not affect the output. Based on BSRIA tests.

Test conditions: LPHW 80°C m.w.t

20°C e.a.t

1.0 m/s water velocity

Output in watts/metre over finned length.

## ELEMENT SUPPORT HANGERS

The single and double hangers illustrated permit the element to move under expansion and contraction. With the element hangers, an angle shelf-bracket for wall fixing is provided together with an M4 x 40 countersunk head screw and nut to enable the element hangers to be suspended from the bracket. Element hangers are made from 1.2mm mild steel; shelf brackets are from 2mm steel. HCP finned-tube elements should be supported at centres of not more than 1500mm. (see diagrams B&C)

## DEPTH OF CASING

To obtain the maximum output, the element must be housed to minimise air by-passing the fins. A maximum dimension of 6mm each side is recommended. (see diagram A)

## ELEMENT LENGTHS

Maximum finned length of a heating element is 3 metres. The manufacturing process ensures that the standard tube diameter is constant along the length. 75mm minimum of plain tube is left at each end. However, where required, fins can be located at any position along the tube.

Diagram A

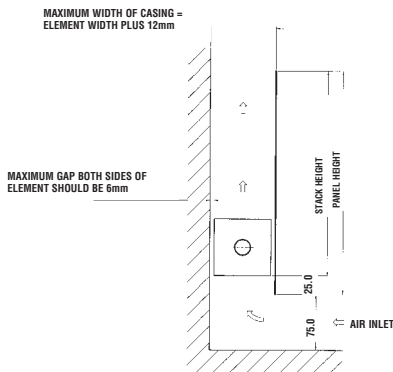

Diagram B

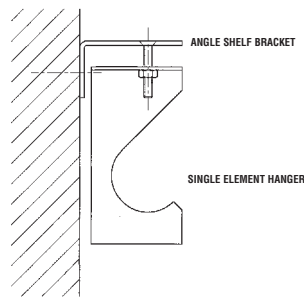
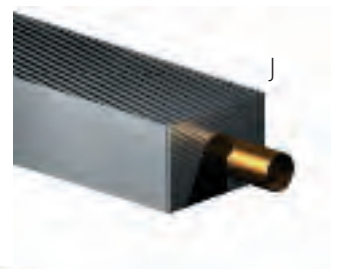
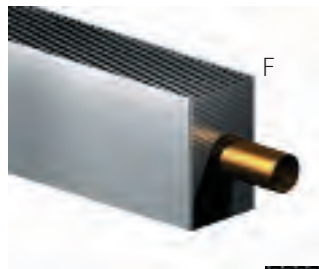
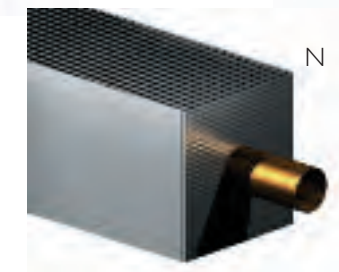
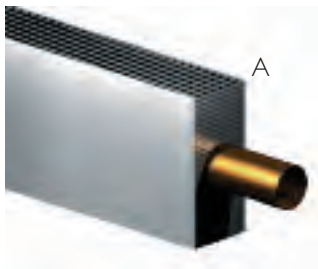

Diagram C



FINNED-TUBE ELEMENT DIMENSIONS	
mm	
Type A	76 x 35
Type F	76 x 50
Type J	50 x 76
Type N	76 x 76
Type W	108 x 108

# Design Applications

Each of the heat outputs listed for our L.P.H.W. Periwarm units are based upon an 80 deg.C m.w.t.\*, 20 deg.C entering air temperature (e.a.t.) and water velocity of 1.0 metre per second (m/s).

For example:

## **Application 1** Calculating a heat output for a different $\Delta t$

Conditions: e.w.t. 82 deg.C, l.w.t. 72 deg.C, e.a.t. 20 deg.C, water velocity 1.0m/s  
Note: e.w.t. should be taken for each installed heating element.

Calculation:  $\Delta t = \text{m.w.t.} - \text{e.a.t.}$

Example:  $\Delta t = \frac{82 + 72}{2} - 20$

$\Delta t = 57 \text{ deg.C}$

When the  $\Delta t$  is 57 deg.C, we can deduce from the correction factor table 'variations in  $\Delta t$ ', that the applicable factor is 0.93. (i.e. listed heat output (W) x 0.93 = Heat Output (W) for the above condition.

## **Application 2** Calculating a heat output for a different water velocity

Conditions: A Periwarm L.P.H.W. floor system, model LTU/JJ is selected to provide a heat output of 3600 Watts given e.w.t. 85 deg.C, l.w.t. 75 deg.C, and e.a.t 20 deg.C ( $\Delta t$  60 deg.C). Given that a water temperature drop (10 deg.C) has been specified, we can deduce the water velocity as follows:

Step 1: Calculate the water mass / flow rate:

$\frac{\text{Heat Output (Watts)}}{\text{e.w.t.} - \text{l.w.t. (deg.C)} \times 4187(\text{J})} = \text{Mass/Flow (kg/s)}$

$\frac{3600}{41,870} = 0.086 \text{ (kg/s)}$

Step 2: Convert mass/flow (kg/s) into water velocity (m/s):

$\frac{\text{Mass/Flow (kg/s)}}{\text{factor } x^{**}} = \text{Water Velocity (m/s)}$

$0.27 \text{ (m/s)} = \frac{0.086}{0.31} = (22 \text{ mm pipe, factor } x^{**} = 0.31)$

From the correction factor table 'changes in water velocity', we can determine that at a velocity of 0.27 m/s we should apply a factor of 0.93 to the listed unit output. From the heat output table, unit LTU/JJ's output/finned metre length is 645 Watts:

$645 \text{ Watts} \times 0.93 = 599.85 \text{ Watts per finned metre}$

In order to meet the 3600 Watt heat requirement, the active length required is:

$\frac{3600 \text{ Watts}}{599.9 \text{ Watts}} = 6.0 \text{ metres}$

## APPENDIX

\*  $\frac{\text{e.w.t.} + \text{l.w.t.}}{2} = \text{m.w.t.}$

\*\*

Tube Dia (mm)	Factor $x$
15	0.14
22	0.31
28	0.52

# Specification

## TRENCH HEATING

**Casing:** Manufactured from 1.2mm thick high grade electro-zinc plated mild steel (Conforming to BS1449 part 1) generally in 1500mm lengths. Internal faces of the casing are to be coated in matt black polyester powder paint. Trench casings are supplied with adjustable feet for on site levelling. Element supports, casing joiners and baffle plates are to be manufactured from 1.2mm electro-zinc plated mild steel and coated in matt black polyester powder paint.

**Grille Type:** Grille shall be manufactured from an aluminium extrusion to BS1474 1987 HE9 TF (6063) with either a 'roll-up' black nylon tube core, or a 'rigid' aluminium tube core. Width and length to suit. Bar height 22mm, bar width 6mm. ('Rigid' grille assembly only for Electric Trench.)

**Grille finish:** Anodised aluminium AA5 to BS1615 (Natural Silver) as standard with polyester powder paint, or colour anodise finish available. Grille edge trims as bar finish and to be self-locating to facilitate separate second fix installation.

### **Element LPHW:**

**Element Fins:** Manufactured from aluminium alloy to BS1470. Aluminium shall be pressed to form a corrugated fin, having spacing collars and interlocking return edges.

**Element Tube:** Manufactured from copper to BS2871 Part 1 C106 type copper and dimensioned as BS2871 part 1, table x. Copper tube is to be mechanically expanded to a standard diameter within the fin.

### **Electric Element:**

**Element:** Element to consist of an 80/20 nickel chrome resistance wire centred in an Incoloy 800 tube. The tube is filled with high quality powdered magnesium oxide insulation and swaged to ensure rapid heat transfer. A crimp wound galvanised steel fin is applied around the sheath. Overall element diameter 29mm.

**Assembly:** The assembly shall be factory fully pre-wired and tested incorporating a high temperature cut out terminal block and (if specified) a control thermostat. The controls wiring is to be housed within an enclosed section painted matt black. The unit will incorporate a black wire mesh guard located above the active element and beneath the grille.

## PERIMETER HEATING

**Front panels & mullions:** Manufactured from 1.2mm thick high grade electro-zinc plated mild steel and finished in polyester powder paint to an approved colour and gloss level. Panel height as required. If specified end caps will be manufactured to suit casing depth and finish. Casings can be mitred and curved.

**Wall Brackets:** Manufactured from 2.0mm thick electro-zinc plated mild steel with all visible parts painted in matt black polyester powdercoat. Element hangers are height adjustable and supplied separately. Floor brackets specification to suit. (application details available upon request.)

**Element Fins:** Manufactured from aluminium alloy to BS1470. Aluminium shall be pressed to form a corrugated fin, having spacing collars and interlocking return edges.

**Element Tube:** Manufactured from copper to BS2871 Part 1 C106 type copper and dimensioned as BS2871 part 1, table x. Copper tube is to be mechanically expanded to a standard diameter within the fin.

**Outlet / Inlet:** Grilles shall be continuous aluminium extrusions to BS1474 1987 HE9 TF (6063). Variable slide grille damper with a rotary controls are available. Open slot or perforation pattern from our standard range also available.

**Grille finish:** Anodised aluminium AA5 to BS1615 (Natural Silver) as standard with polyester powdercoat or colour anodised finish available.

## HCP Product Portfolio



Trench & Perimeter Heating

**PERIWARM** range of trench and perimeter heating systems



Radiant Heating

**PERIWARM** range of radiant heating solutions for incorporation into a ceiling grid, freely suspended or surface mounted



Intergrated Service Modules

**COOLCEIL** range of intergrated service modules incorporated cooling, lighting, speakers, PIR primary pipework and cabletrays



Chilled Ceilings & Beams

**COOLCEIL** range of chilled, radiant and convective cooling ceiling solutions.

**HCP**  
Heating & Cooling

**HCP: A Division of SAS International**  
Chichester Road, St. Leonards-on-Sea,  
East Sussex TN38 9BG  
Tel: 01424 712195  
Fax: 01424 457331  
info@hcp-sasint.co.uk  
www.hcp-sasint.co.uk

**SAS**

**SAS International**  
31 Suttons Business Park  
London Road Reading Berkshire RG6 1AZ  
Tel: +44 (0)118-929 0900  
Fax: +44 (0)118-929 0901  
www.sasint.co.uk  
enquiries@sasint.co.uk